

Werkstoff: PVC / PPs / PP / PE

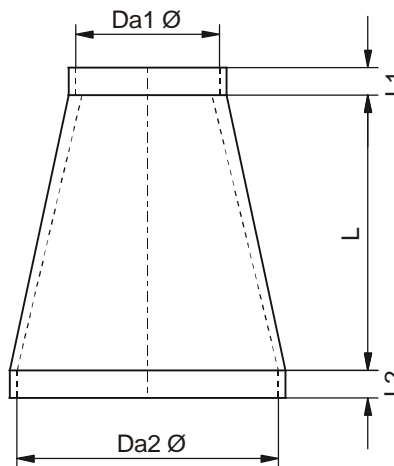
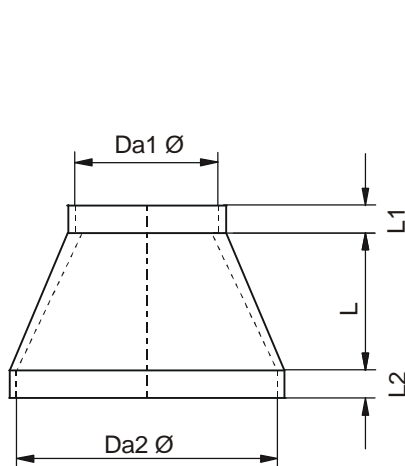

Zeta-Beiwert $Da2 \sim Da1 = 0 \sim 0,5$

Da 1 Ø	Da 2 Ø	L	L1	L2
75	90	40	40	40
75	110	80	40	40
90	110	60	40	40
110	125	40	40	40
110	140	80	40	40
110	160	140	40	40
110	180	50	40	40
110	200	65	40	40
125	140	40	40	40
125	160	100	40	40
125	180	40	40	40
125	200	55	40	40
125	225	65	40	40
125	250	90	40	40
140	160	60	40	40
140	180	30	40	40
140	200	45	40	40
140	225	60	40	40
140	250	80	40	40
160	180	60	40	40
160	200	120	40	40
160	225	100	40	40
160	250	120	40	40
160	280	85	40	50
160	315	115	40	50
180	200	75	40	40
180	225	85	40	40
180	250	100	40	40
180	280	65	40	50
180	315	100	40	50

Da 1 Ø	Da 2 Ø	L	L1	L2
200	225	80	40	40
200	250	140	40	40
200	280	105	40	50
200	315	160	40	50
200	355	115	40	50
225	250	80	40	40
225	280	40	40	50
225	315	65	40	50
225	355	95	40	50
225	400	125	40	50
250	280	35	40	50
250	315	100	40	50
250	355	140	40	50
250	400	105	40	50
250	450	145	40	50
280	315	100	50	50
280	355	65	50	50
280	400	90	50	50
280	450	120	50	50
280	500	160	50	50
315	355	20	50	50
315	400	120	50	50
315	450	95	50	50
315	500	135	50	50
355	400	135	50	50
355	450	75	50	50
355	500	110	50	50

andere Abmessungen auf Anfrage